

FEATURES

- Forged brass valve body
- Single-handle temperature control
- High-temperature limit stop for added safety
- Temperature-balancing mechanism
- Scald hazard prevention
- Integral stops
- Crossflow prevention
- 1/2" NPT connections
- Filter screens
- Single outlet
- Less volume control
- 10.9 gal/min (41.3 l/min) maximum flow rate at 45 psi (310.3 kPa)

CODES/STANDARDS APPLICABLE

- Specified model meets or exceeds the following:
- ASME A112.18.1/CSA B125.1
 - ASSE 1016

P29511

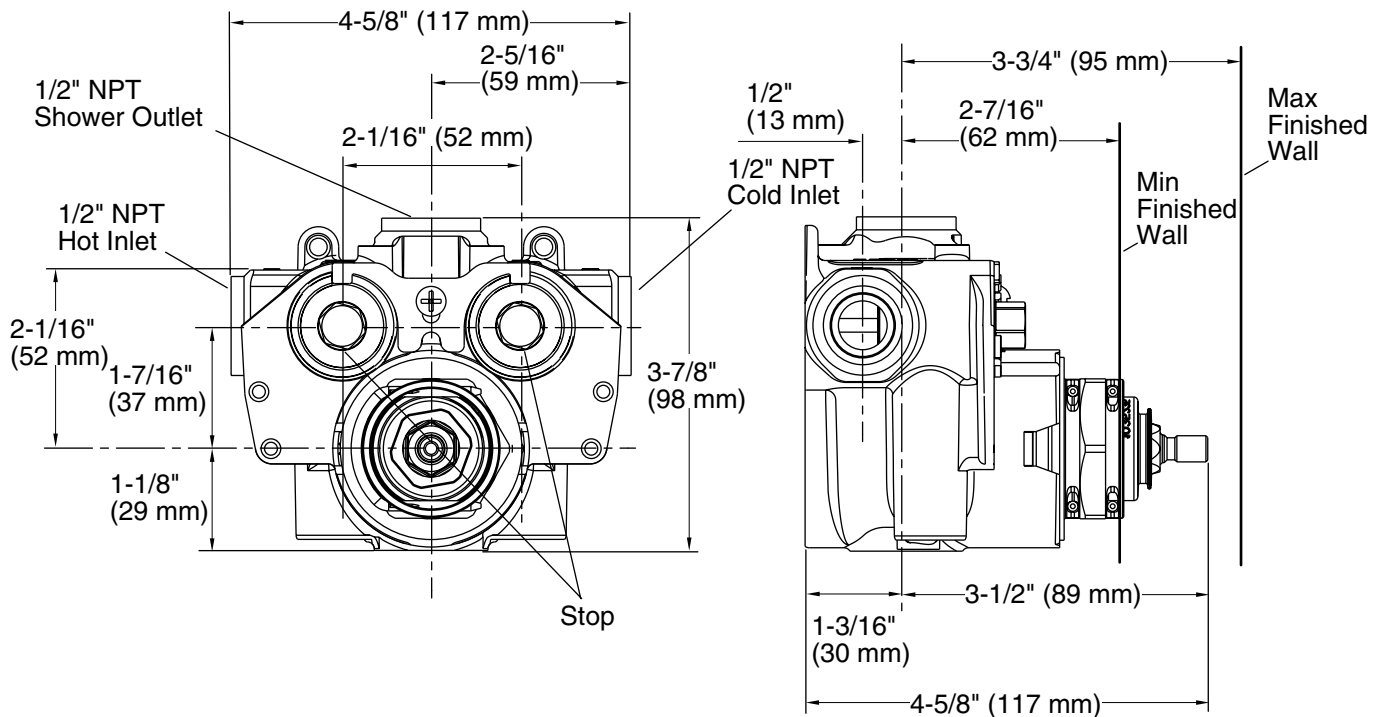

SPECIFIED MODEL		
Model	Description	Finishes
P29511-WS	1/2" Thermostatic Mixer Valve	<input type="checkbox"/> NA
Required Accessories		
P29527-00	1/2" Volume Control Valve - for use on bath or shower outlets	<input type="checkbox"/> NA

We reserve the right to make revisions without notice in the design of products or in packaging unless this right has specifically been waived at the time the order is accepted.